

ELMARK[®]

The Brand of Electricity

**LED FIXTURES WITH ADJUSTABLE
COLOUR TEMPERATURE AND
SENSOR**



Technical data:

- Input Voltage: 110-240 VAC
- Power: 18W;
- Colour temperature: 3000/4000/6000K- Adjustable
- Light source: Sanan SMD2835
- Colour: White;
- Body: Aluminium
- Beam angle: 110°
- Colour rendering index: Ra≥80
- Switch on/off: >20 000
- Long life: 30 000h
- Starting time: < 0,5s
- Power factor: $\lambda > 0.9$
- Installation: Surface mounting
- Protection against dust and moisture: IP40

Features:

- Completely replace traditional lighting fixtures
- Instant start, no flickering, no humming
- 3 options to changes colour temperature with the push of a button
- Microwave sensor presence detection option
- Safety, low voltage operation
- Emit a very pleasant and even light with very low glare factor due to the diffusion lens
- Low power consumption
- Repeated switch-on/off does not affect the lifespan of the LED panel
- Environmentally friendly - do not emit mercury and lead (RoHS Directive)
- No ultraviolet and infrared rays
- Resistant to shock and vibration

TECHNICAL SPECIFICATION

INDOOR-LED PANELS

ELMARK[®]

The Brand of Electricity

Area of application:

- Residential buildings
- Administrative buildings
- Banks
- Hospitals
- Schools

Variants and Dimensions:

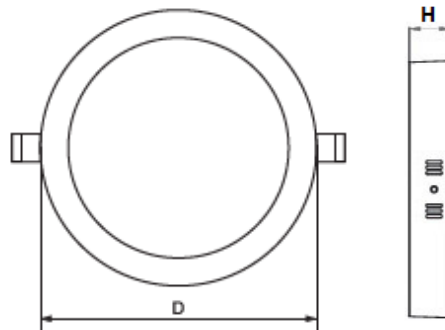

Watt	Whole fixture lumens	Colour temp.	Colour body	Size (mm)		Catalogue number
(W)	(lm)	(K)		Diameter	Height	
18W	1440	3000/4000/6000	White	220	18.8	99DS407



TECHNICAL SPECIFICATION

INDOOR-LED PANELS

ELMARK[®]

The Brand of Electricity

Barcodes:

3800131214270

99DS407

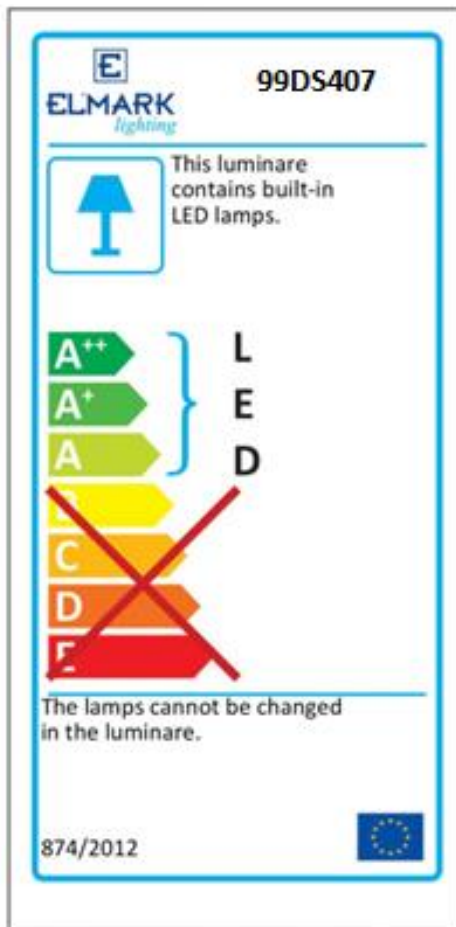

EN 55015 • EN 61000-3-2 • EN 61000-3-3 • EN 61547 • EN 60598-1 • EN 60598-2-2 • EN 13032-4 • EN 50581:2012

CE RoHS COMPLIANT

www.elmarkholding.eu