

EL[®]MARK

The Brand of Electricity

LED PANELS ROUND IP65

GENERAL INFORMATION »

- ∴ Nominal voltage: 85-2650V/ 50-60Hz
- ∴ Power: 5W; 10W; 18W;
- ∴ Power supply: Control gear; DC device- driver
- ∴ Light source: Epistar SMD
- ∴ Colour temperature: 4000K; 6500K
- ∴ Colour body: White
- ∴ Housing: Polycarbonate (PC)
- ∴ Reflector: Polycarbonate (PC)
- ∴ Beam angle: 120°
- ∴ Colour rendering index: Ra≥80
- ∴ Switch on/off:>20 000
- ∴ Long life: 30 000h
- ∴ Starting time: <0.5s
- ∴ Power factor: $\lambda > 0.8$
- ∴ Protection against dust and moisture: IP65
- ∴ Installation: Built-in
- ∴ Available in variant with an emergency kit



FEATURES »

- ∴ Completely replace traditional fluorescent lighting
- ∴ Safety, low voltage operation
- ∴ Emit a very pleasant and even light with very low glare factor due to the diffusion lens
- ∴ Low power consumption
- ∴ Instant light with maximum luminous flux
- ∴ Environmentally friendly - do not emit mercury and lead
- ∴ No ultraviolet and infrared rays
- ∴ Resistant to shock and vibration
- ∴ Easy installation due to handy clips
- ∴ Suitable for home, offices, halls, shops, hospitals
- ∴ Ideal for places with high level of moisture

PRODUCT DETAILS »

Catalogue number	Catalogue number with Emergency kit	Watt (W)	Whole fixture lumens (lm)	Colour temp. (K)	Colour body
99LED609IP65	99LED609IP65E	5	400	4000	white
99LED609IP65CW	99LED609IP65CWE	5	400	6500	white
99LED611IP65	99LED611IP65E	10	800	4000	white
99LED611IP65CW	99LED611IP65CWE	10	800	6500	white
99LED617IP65	99LED617IP65E	18	1440	4000	white
99LED617IP65CW	99LED617IP65CWE	18	1440	6500	white

DIMENSIONS »

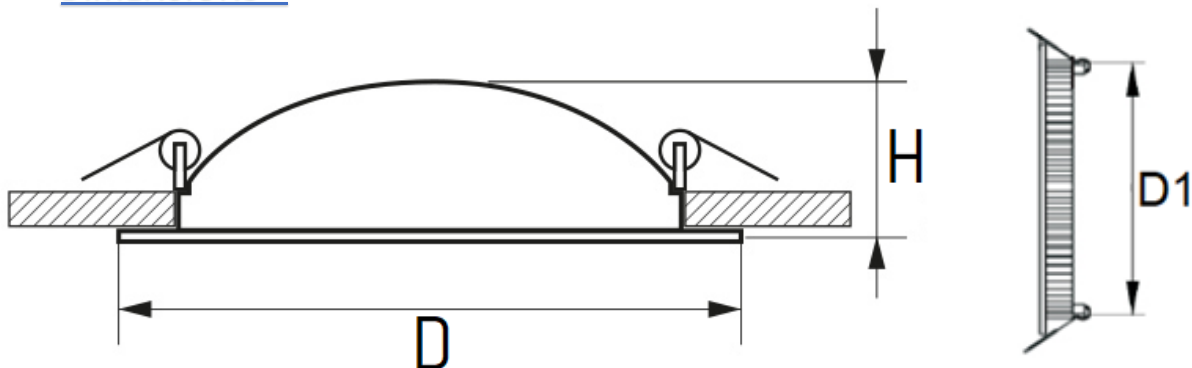

Catalogue number	Diameter (mm)	Height (mm)	Diameter1 /Cut out/ (mm)
99LED609IP65	88	30	70
99LED609IP65CW	88	30	70
99LED611IP65	150	27	130
99LED611IP65CW	150	27	130
99LED617IP65	225	27	200
99LED617IP65CW	225	27	200

LED EMERGENCY KIT SPECIFICATIONS »



General information »

- ∴ Voltage: AC85-265V 50Hz
- ∴ Emergency Output: 3-40W
- ∴ Emergency Time: 2hrs (120mins)
- ∴ Battery: 3.7V 2400mAh
- ∴ Emergency Switching Time: <2s
- ∴ AC Fuse: 250V 1A
- ∴ DC Fuse: 250V 5A
- ∴ Luminous Flux: >100lm
- ∴ Light Source: LED
- ∴ Working temperature: -10°C +55°C
- ∴ IP Rate: IP30

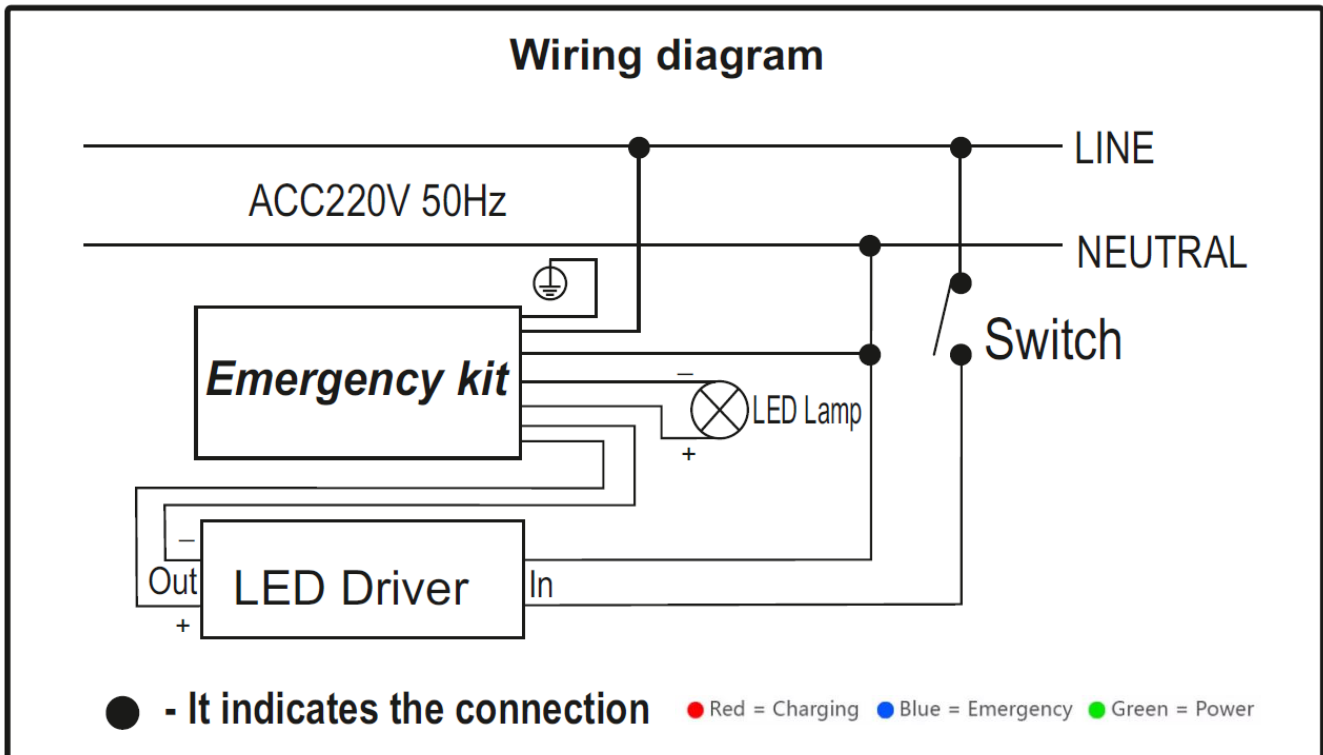
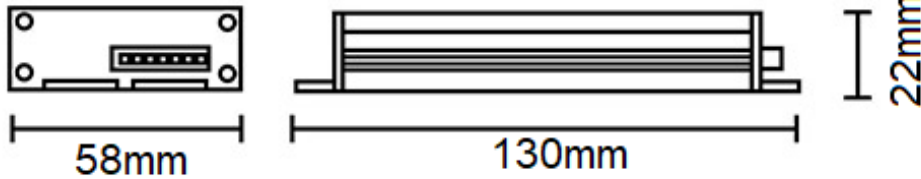

ADDITIONAL INFORMATION »



99LED609IP65



This luminaire contains built-in LED lamps.

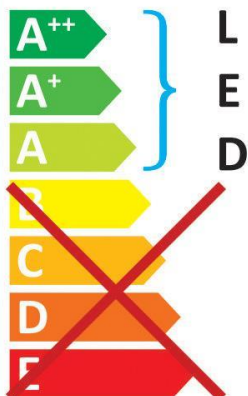

The lamps cannot be changed in the luminaire.

874/2012



Catalogue number	Barcode	Packing/Box (pcs)
99LED609IP65	3800131192233	1/40
99LED609IP65CW	3800131210678	1/40
99LED611IP65	3800131192240	1/40
99LED611IP65CW	3800131210685	1/40
99LED617IP65	3800131192257	1/20
99LED617IP65CW	3800131210692	1/20

